

4

3

2

1

ZONE	REV.	REVISION DESCRIPTION	ECN NO.	DATE

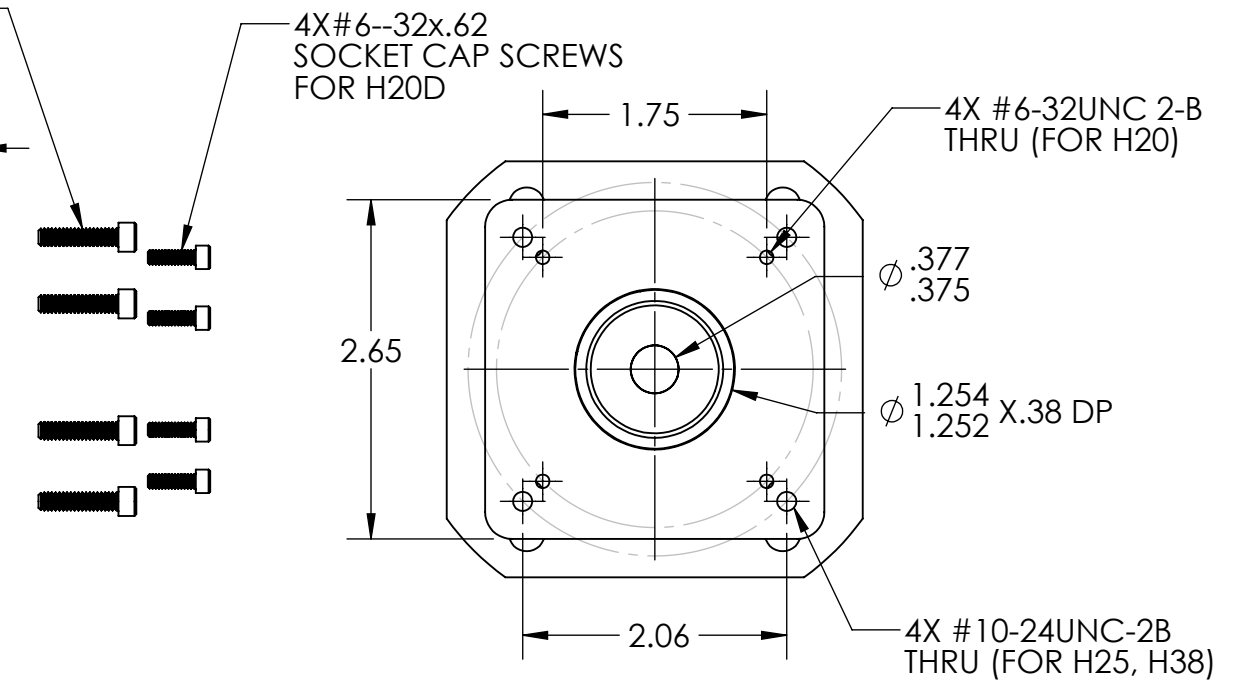
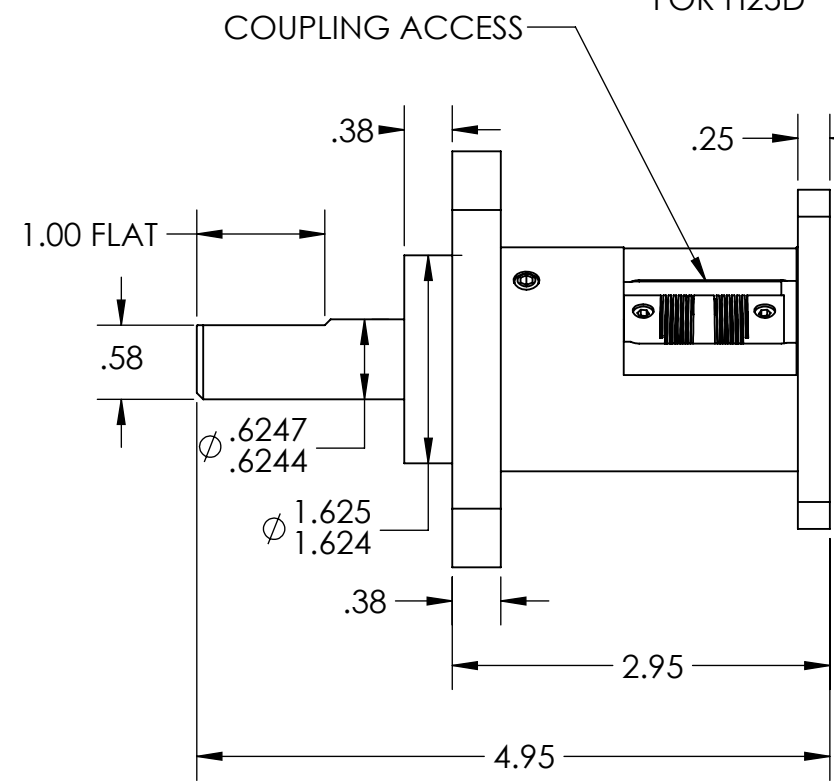
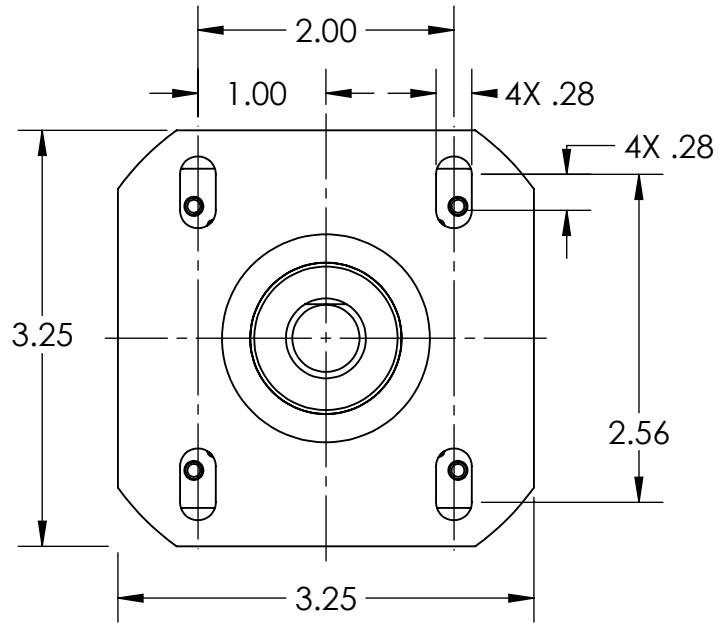

**11008-000**  
 HIGH-LOAD BEARING  
 ASSEMBLY INCLUDES HARDWARE  
 FOR BOTH H25D AND H20D  
 (SOLD SEPARATELY)

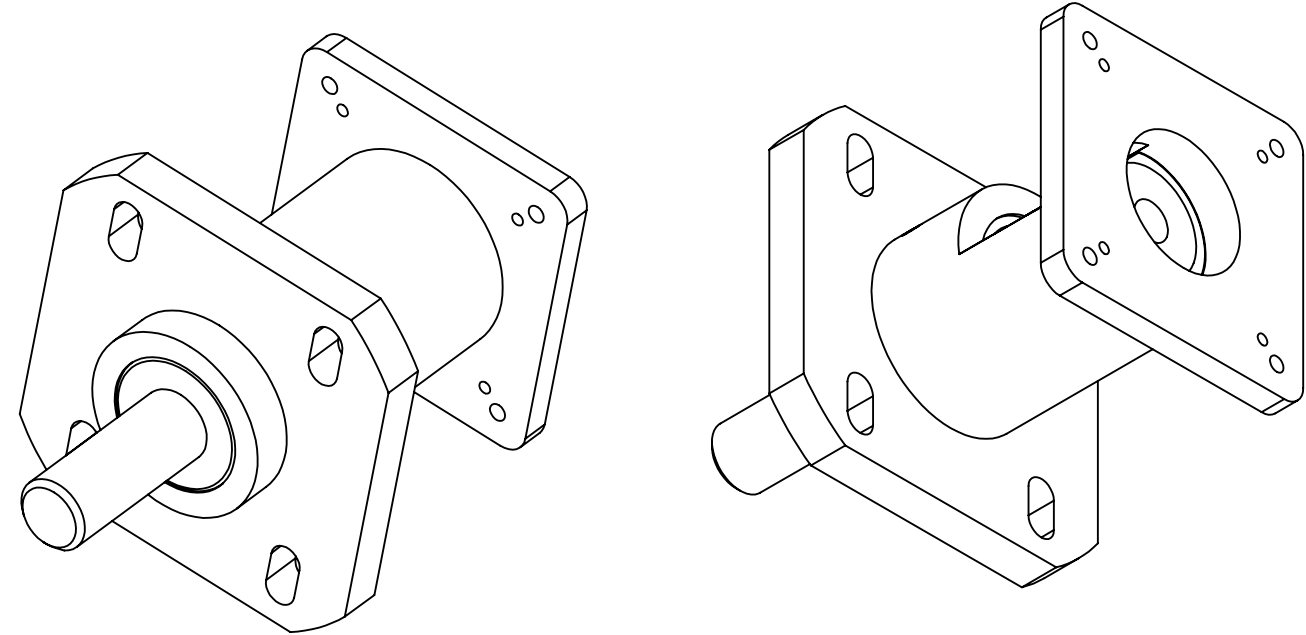

- NOTES (UNLESS OTHERWISE INDICATED)
- SQUARE, FLANGE MOUNT HIGH-LOAD BEARING ASSEMBLY.
  - FOR USE WITH H20D, H25D, AND H38 ENCODERS. SEE SHEET 2 OF 2 FOR DETAILS.

<b>UNCONTROLLED COPY</b>		 BEI SENSORS 1461 LAWRENCE DRIVE THOUSAND OAKS, CA 93120
FIRST ISSUE DATE: 04/08/19 DRAWN: DRC APPROVED: MFB DATE: 04/08/19	SENSATA TECHNOLOGIES PROPRIETARY AND CONFIDENTIAL. NEITHER THIS PRINT NOR THE INFORMATION CONTAINED HEREON IS TO BE USED AGAINST THE INTERESTS OF SENSATA TECHNOLOGIES OR AGAINST THE INTERESTS OF ANY OF ITS AFFILIATED COMPANIES OR WHOLLY OWNED SUBSIDIARIES.	
ECN: DATE: MATERIAL:	INTERPRET DIMENSIONING AND TOLERANCING PER ASME Y14.5-2009. UNLESS OTHERWISE SPECIFIED DIMENSIONS ARE IN INCHES [MILLIMETERS] AND ARE INTENDED AS NOMINAL SEE PRODUCT SPECIFICATIONS FOR MORE DETAILS.	TITLE <b>SQUARE FLANGE MOUNT          HIGH-LOAD BEARING          ASSEMBLY</b>
DO NOT SCALE DRAWING	THIRD ANGLE PROJECTION	SIZE DWG NO. REV. <b>B 09905-001 A</b>
SCALE 1:1.5 SOLIDWORKS SHEET 1 OF 2		

4

3

2

1

DEVICE: PROJECT:

4

3

2

1

ZONE	REV.	REVISION DESCRIPTION	ECN NO.	DATE

**11008-004**  
HIGH-LOAD  
BEARING ASSY FOR  
H38 UL OR H38 CEN  
(SOLD SEPARATELY)

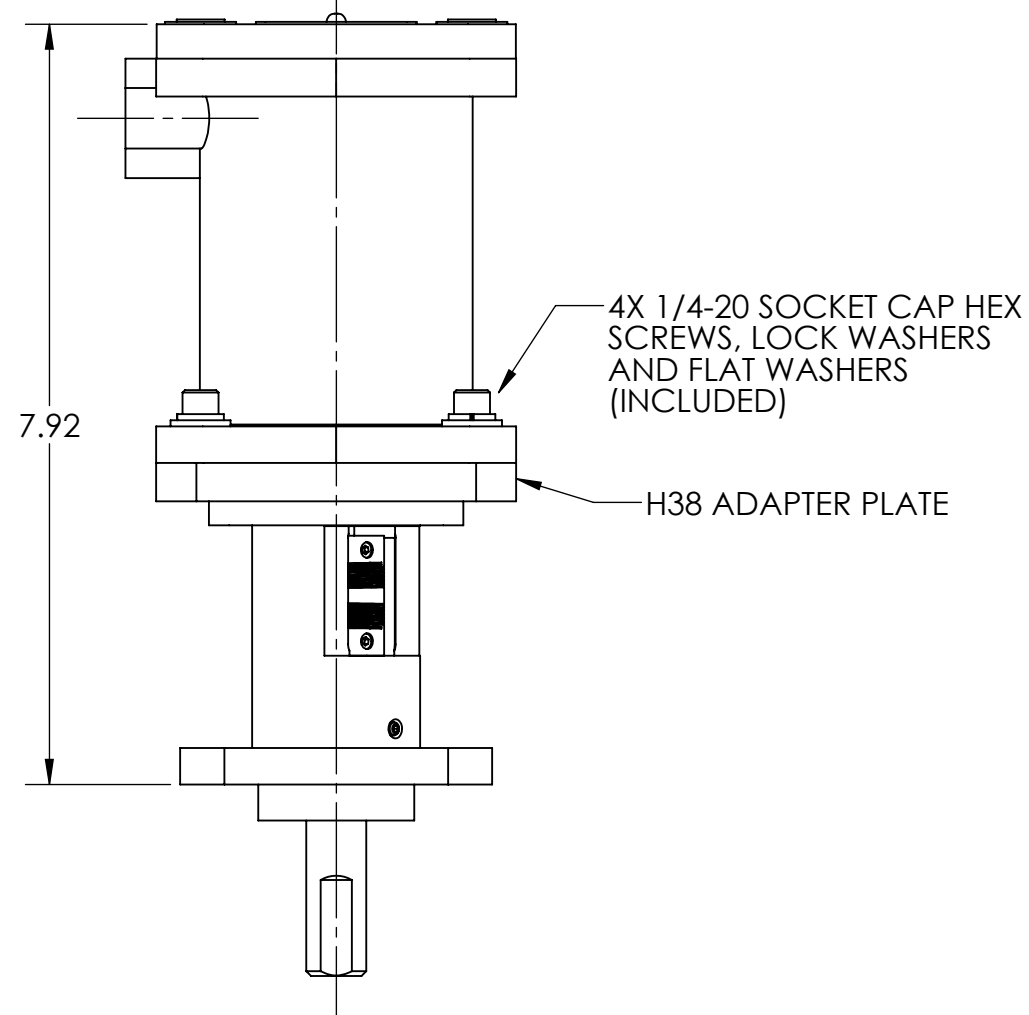

**11008-002**  
HIGH-LOAD BEARING  
ASSEMBLY FOR H25D  
(SOLD SEPARATELY)

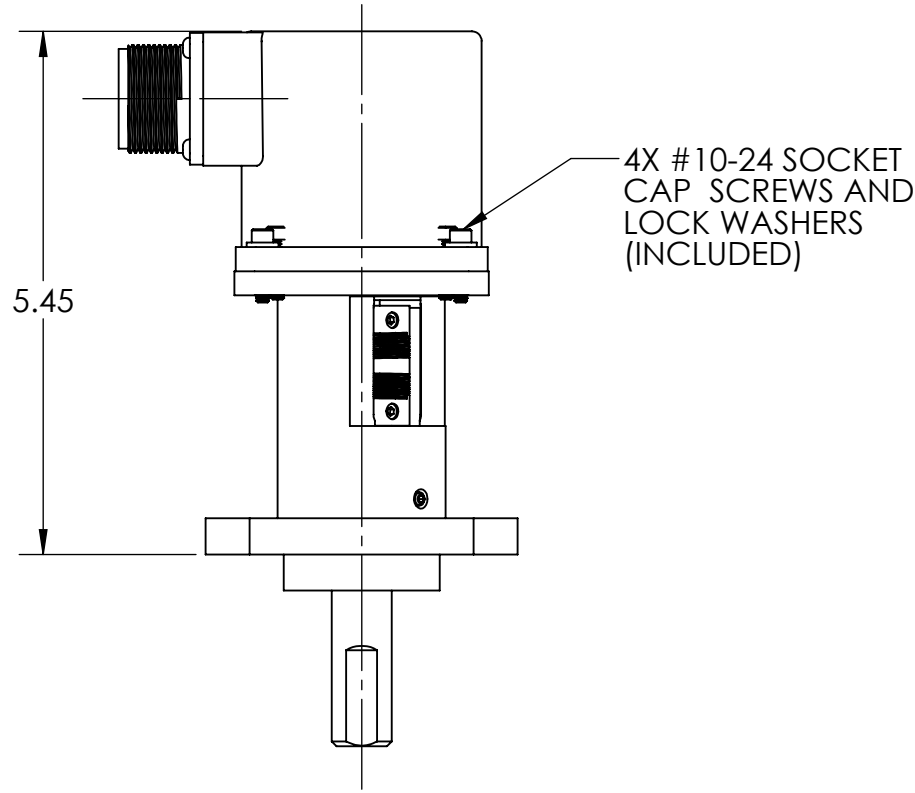

**11008-003**  
HIGH-LOAD BEARING  
ASSEMBLY FOR H20D  
(SOLD SEPARATELY)

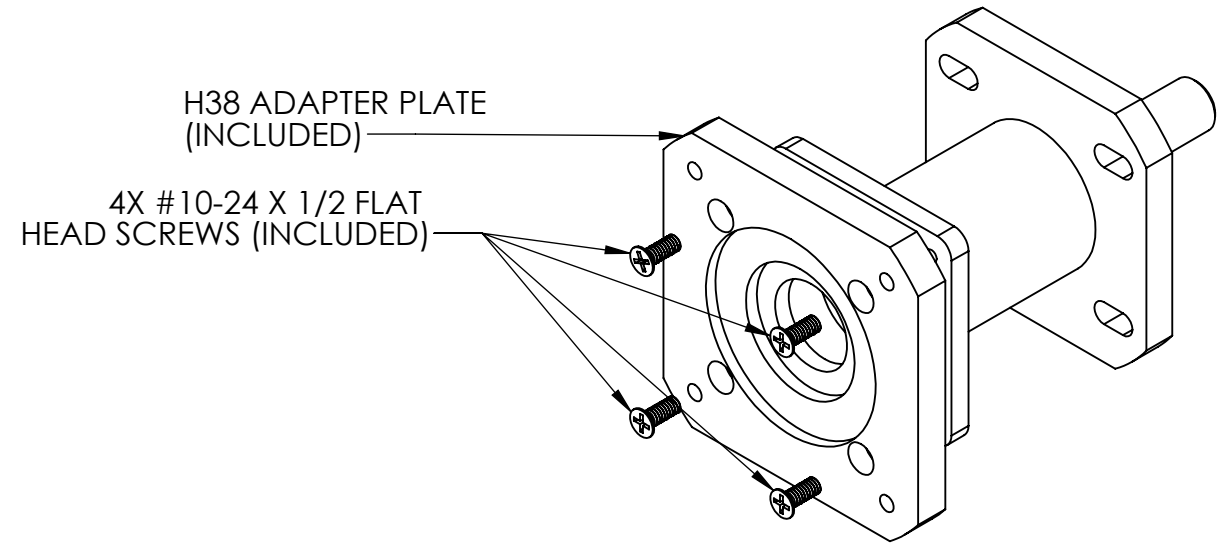
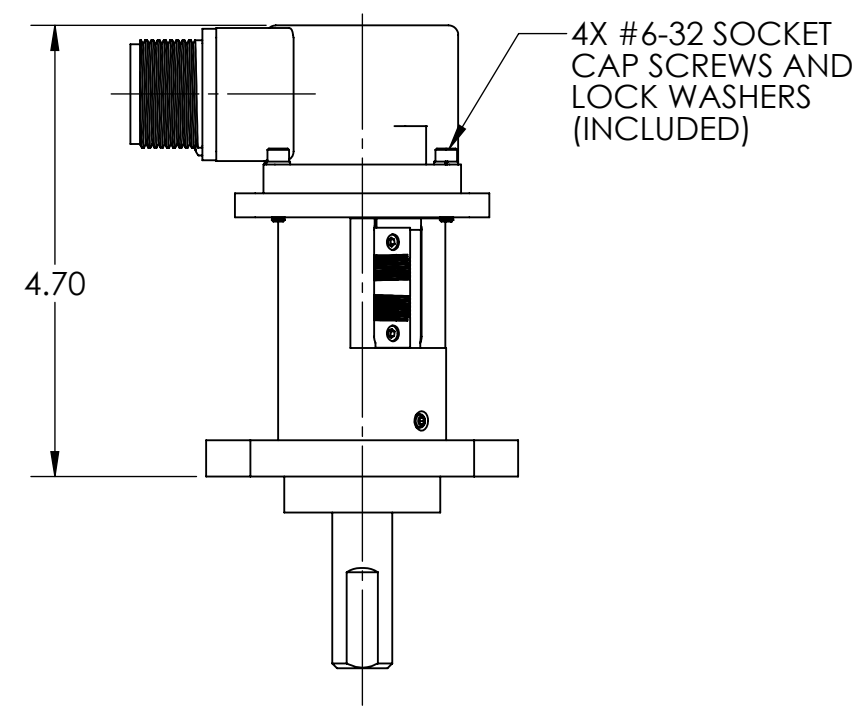

**UNCONTROLLED COPY**

FIRST ISSUE DATE: 04/08/19  
DRAWN: DRC  
APPROVED: MFB  
DATE: 04/08/19  
ECN:  
DATE:  
MATERIAL:

SENSATA TECHNOLOGIES PROPRIETARY AND CONFIDENTIAL. NEITHER THIS PRINT NOR THE INFORMATION CONTAINED HEREON IS TO BE USED AGAINST THE INTERESTS OF SENSATA TECHNOLOGIES OR AGAINST THE INTERESTS OF ANY OF ITS AFFILIATED COMPANIES OR WHOLLY OWNED SUBSIDIARIES.

INTERPRET DIMENSIONING AND TOLERANCING PER ASME Y14.5-2009. UNLESS OTHERWISE SPECIFIED DIMENSIONS ARE IN INCHES [MILLIMETERS] AND ARE INTENDED AS NOMINAL SEE PRODUCT SPECIFICATIONS FOR MORE DETAILS.

DO NOT SCALE DRAWING  
THIRD ANGLE PROJECTION

**Sensata Technologies**  
BEI SENSORS  
1461 LAWRENCE DRIVE  
THOUSAND OAKS, CA 93120

TITLE  
**SQUARE FLANGE MOUNT  
HIGH-LOAD BEARING ASSY  
WITH ENCODER OPTIONS**

SIZE DWG NO. REV.  
**B 09905-001 A**

SCALE 1:2 SOLIDWORKS SHEET 2 OF 2

4

3

2

1

DEVICE: PROJECT: